

FE MODELLING OF SANDWICH PANELS WITH SCREWED JOINT AT ELEVATED TEMPERATURES

Ashkan Shoushtarian Mofrad¹, Darita Shlychkova², Yvonne Ciupack³, Hartmut Pasternak⁴

Brandenburg University of Technology, Cottbus, Germany

Abstract:

Understanding and predicting sandwich structure behavior in fire has been of particular interest to researchers for a long time. Sandwich panel joints are playing an important role since they not only connect sandwiches to a bearing structure, but also play a key role in stabilization of the whole building. This paper presents an investigation of a sandwich panel behavior. The sandwich panel consist of two steel layers and PIR core between them and is connected to a HEA 160 flange with the help of a screw. Using ABAQUS software, this connection is modelled and deformation fields with temperature distribution area are analyzed. The modelling process includes many stages associated with each other: static, heat transfer and sequential analysis that includes both previous analyses.

Key words: *stabilization, translational stiffness, PIR-core, screwed joints, sandwich panels, fire resistance, finite element modelling*

1. Introduction

Due to the fact that the strength of most materials decreases at high temperatures, the developing heat during a fire can lead to significant damage to a construction. Exactly that factor has played a critical role in well-known catastrophic collapse of buildings, such as the World Trade Center Twin Towers in New York and the Windsor Tower in Madrid. A recent fire disaster in an industrial steel building in Lohne, Germany, March 28, 2016 [1], showed that vertical sandwich panels resisted fire rather well and proved the important role of connectors. Later, in June 8, 2016 a fire occurred in an exhibition hall in Düsseldorf, Germany [2]. The behavior of the sandwich panels was very similar. These recent events confirm the importance of this research and point out to lack of prevention information for fire disasters.

All buildings must resist fire according to the local fire regulations. In Eurocode 3, there are the given main rules for design of steel structures in fire conditions [3]. The

¹ Ashkan Shoushtarian Mofrad, PhD student, ashkan.shoushtarian@b-tu.de

² Darita Shlychkova, PhD student, shlychkova@b-tu.de

³ Yvonne Ciupack, Dr.-Ing., yvonne.ciupack@b-tu.de

⁴ Hartmut Pasternak, Prof. Dr.-Ing. habil., Hartmut.Pasternak@b-tu.de ,
all: BTU, K.-Wachsmann-Str.2, 03046 Cottbus, Germany

members can be stabilized with trapezoidal sheeting and with sandwich panels. In fire not only the entire sheeting and panels but also the connectors are attacked by the fire and their properties change. The ISO 834 is an International Standard containing information about fire, which is not realistic but can lead to useful results in the analysis [4].

2. General information

The focus of this research is to evaluate the translational behavior of a sandwich panel and its joint supporting by H-profiled beam section during fire. The geometry and materials are typical for single storey industrial or commercial buildings.

Using ABAQUS software [5], the translational stiffness of the mentioned joint is studied under shear loads. For this, the bolted joint of a sandwich panel with PIR core and a HEA 160 beam at ambient and at elevated temperatures (in fire) are simulated. The temperature rise assumed is according to ISO 834 until 600°C [4].

3. Geometry of the connection

Fig. 1 shows the studied connection between the sandwich panel and the beam flange of a HEA 160. The bottom sheet models the flange of HEA160 which is considered to be a partial element of the bearing structure. The sandwich panel consists of PIR core along with inner and outer steel facings with 0.5 mm thickness. The sandwich panel is fastened to the support sheet by screw of 5.5 mm diameter.

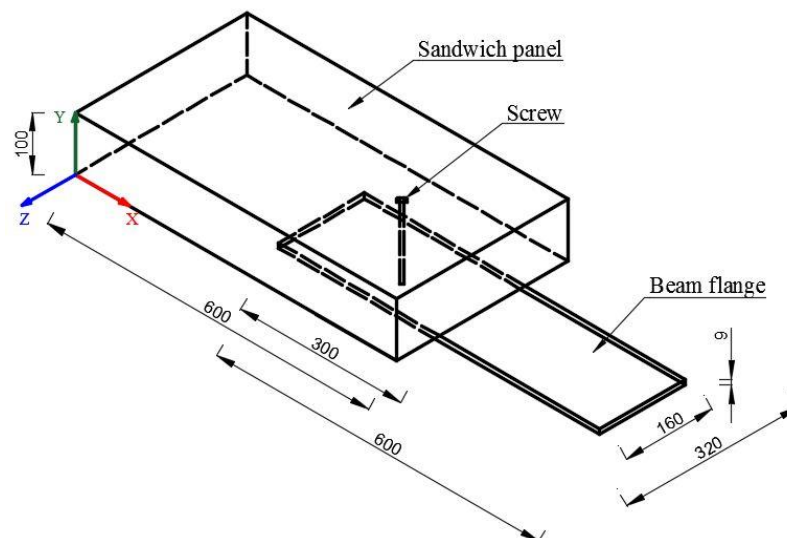

Fig. 1. Dimensions of structural model with screw

The diameter and thickness of the bolt head are 11 and 2.4 mm respectively. The overlap length of sandwich panel and beam flange is 300 mm, where the bolt is located in the centre.

4. Boundary conditions and loading

The boundary conditions are defined so that the left end of the sandwich panel is fixed in X and Y directions (see Fig. 2). The front side of the whole structure is laterally restrained in Z direction, and the right end of the flange is fixed in Y but free in X direction. Displacement controlled loading is applied to the end of the flange until a maximum value of 4 mm is achieved. The screw transfers maximum force at 4 mm displacement. It is specified according to a monotonic analysis in normal condition.

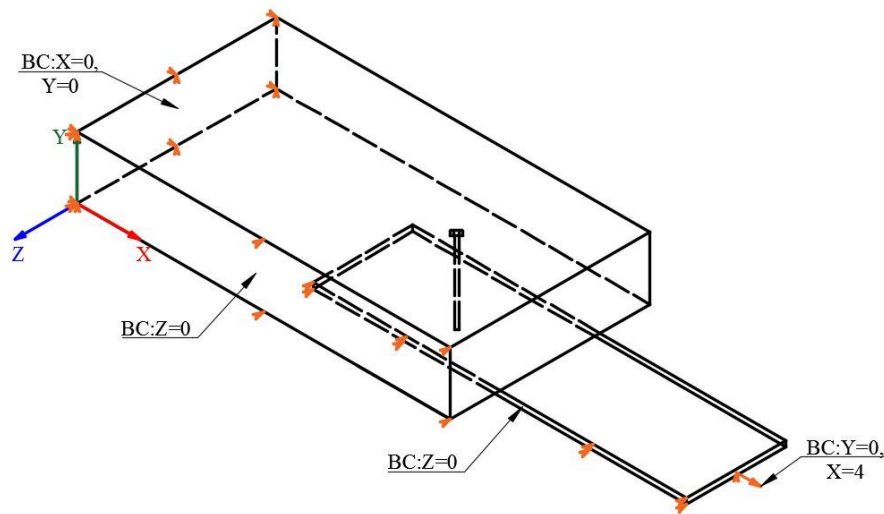

Fig. 2. Boundary condition and loading

5. Material properties

The material used for the flange, facings and screw is assumed to be steel grade S355. Material stress-strain curves are defined according to EN 1993-1-2 [3] in general and for the studies at ambient temperature this curves are transferred to true stress-strain curves up to an engineering strain of 0.15.

All mechanical properties for PIR core such as thermal conductivity, specific heat, as well as elastic and plastic properties are taken from the literature [6]. In Table 1, the values of thermal conductivity of the studied PIR core at normal and elevated temperatures are shown.

Table 1. Values of thermal conductivity at normal and elevated temperatures for PIR core [6]

Temperature T (°C)	Effective Thermal Conductivity λ^* (W/mK)
1	0.029
20	0.031
50	0.034
100	0.039
200	0.051
300	0.065
400	0.083
500	0.104
600	0.130
700	0.162
800	0.199
900	0.242
1000	0.293

6. Contact interaction

One of the key issues in the analysis of bolted joints is to simulate the interacting components. In this study, the contact between facings and PIR core is defined by Tie, where the facing is the master surface and the core the slave surface. By Tie interaction, the temperature in the vicinity of two different connected surfaces is equal. Surface to

surface contact is used between the screw head and the upper facing, the shank screw and the sandwich panel, the flange and the lower facing. For the contact interaction property, normal behavior “hard contact” in order to prevent any penetration of parts and tangential behavior with friction coefficient of 0.2 are taken into account. Generally, tougher surfaces with finer mesh are considered as master surfaces in which in this study, the bolt surfaces are tougher [5].

7. FE modelling

In this study, 3D finite element model is developed using ABAQUS software [5] in order to simulate the translational connection of sandwich panel under static shear at both ambient and elevated temperatures. The model considers the material nonlinearity, geometric nonlinearity and contact behavior.

Three dimensional eight node solid elements with reduced integration points (C3D8R) are chosen for modelling the PIR core, screw and beam flange, while in order to improve the computational efficiency, the facings are simulated by S4R shell elements. The screw which has more importance within this study, has finer mesh.

There are two different types of analyses in this study: First a static general analysis in normal condition and second a sequential analysis. For the second one, the analysis is carried out in two phases: The mechanical loading is applied first and then by keeping the mechanical loading constant, the temperature is increased according to ISO standard fire [4] curve as shown in Fig 3. Heat loading is exposed to the bottom face of the flange.

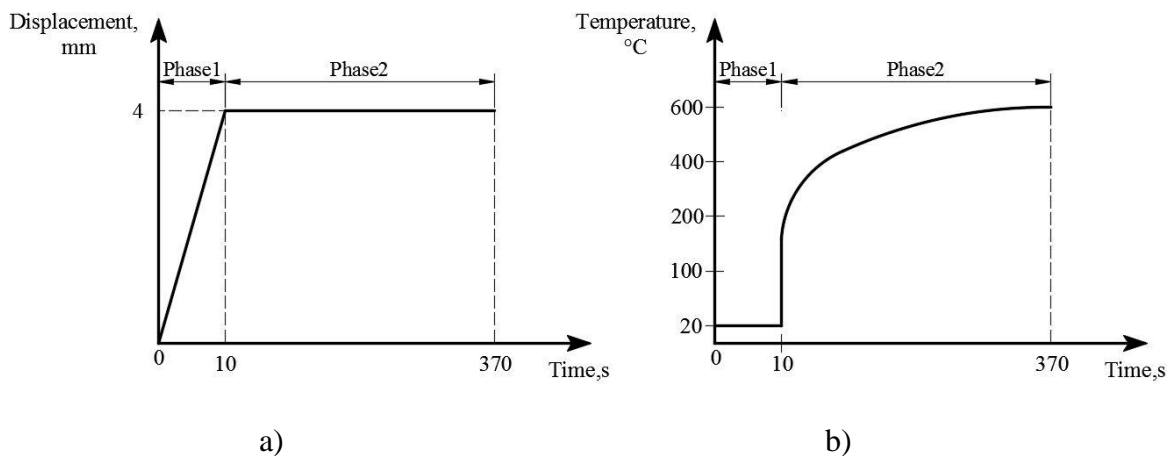

Fig. 3. Loading: a) mechanical displacement to the structure; b) temperature increase to the structure

8. Results and discussion

As it can be seen, the strength due to the degradation of material is reduced when the temperature increases. In fact, at the time of 10 seconds when the fire starts, the maximum of the transferred force is 2314 N, and after that at the temperatures of 100 °C, 200 °C and 300 °C, the value of the force has been decreased to 2084 N, 708 N and around zero, respectively. Therefore, at 300 °C, the failure and collapse of the joint has been observed.

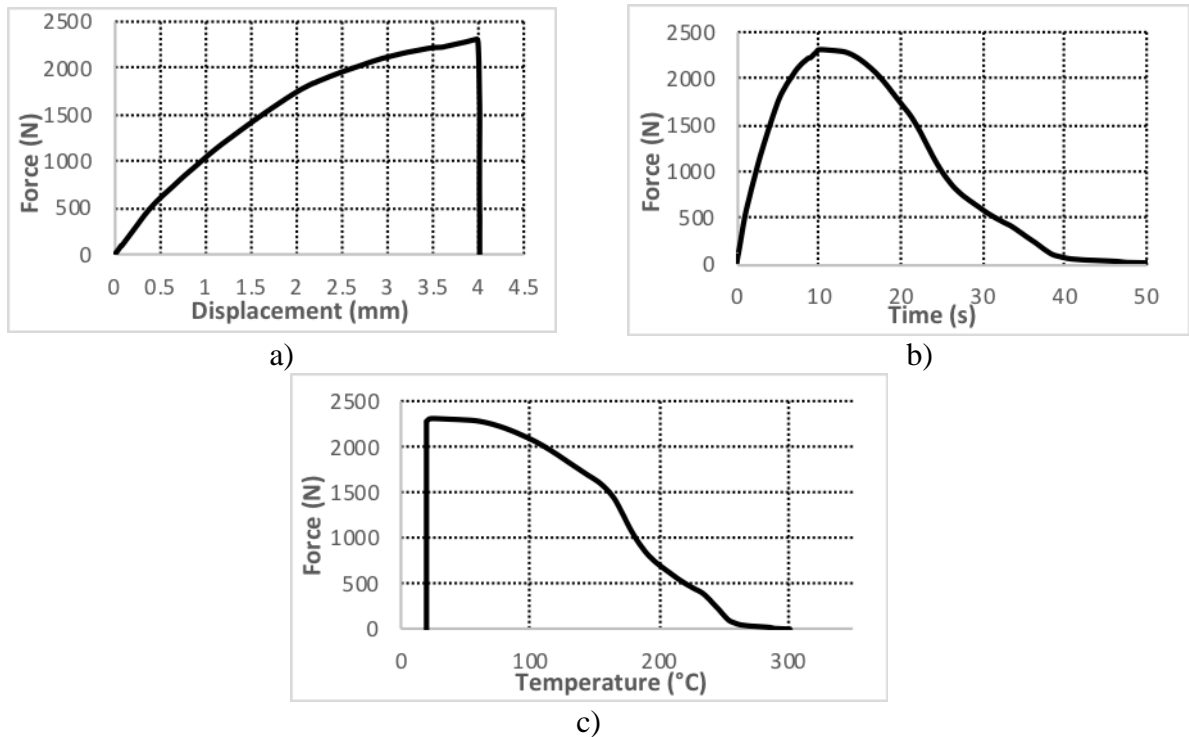

Fig. 4. Translational behavior of the structure: a) displacement – force; b) time – force; c) temperature – force

In the beginning of the deformation, due to the eccentricities of the applied load to the whole model, a positive bending (based on Timoshenko theory) in the connection is created which causes an upward movement in the middle of the model. This movement continues until 10 s and after that by increasing temperature, due to thermal bowing in the flange, a downward movement is observed, as expected.

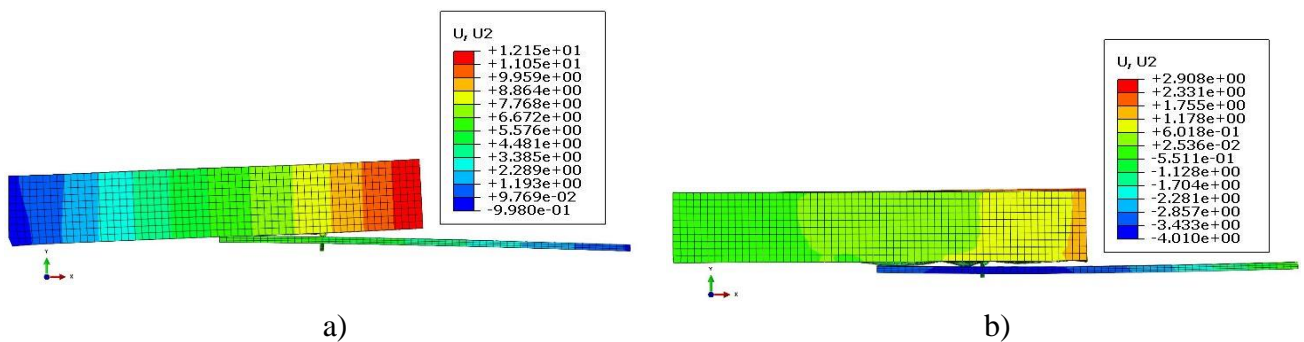

Fig. 5. Displacement in Y direction (in mm): a) at 20 °C; b) at 300 °C

The Fig.5 indicates properly the importance of joints during fire. As it is seen, the maximum heat transfer occurs through the joint, thus the vulnerability of the structure due to degradation of screw material is more substantial when compared to other parts of the structure; in fact, this event turns the joints to weak points of structures at elevated temperature.

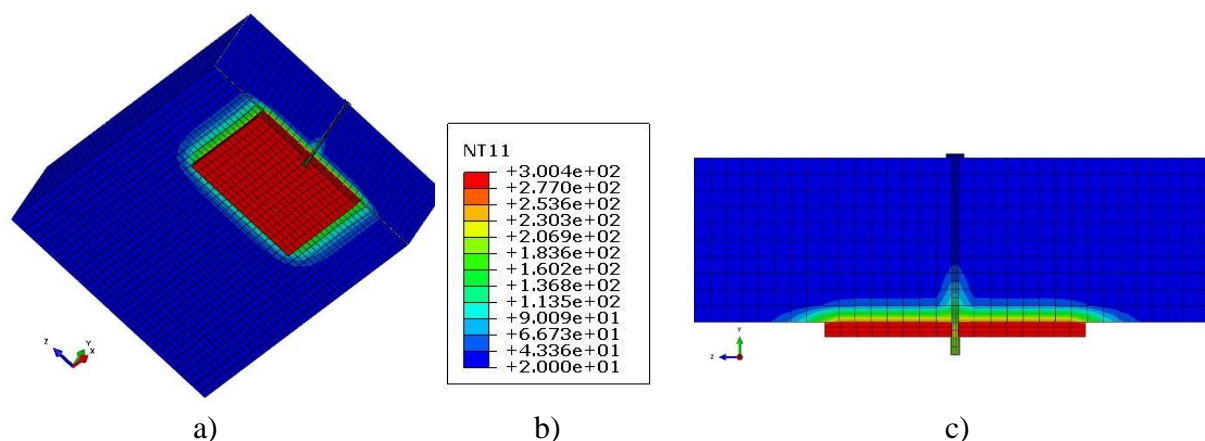

Fig. 6. Temperature distribution of the structure: a) bottom view of the specimen; b) values of temperature ($^{\circ}\text{C}$); c) side view

9. Conclusions

A 3D finite element model including material non-linearity, geometric non-linearity and contact interaction have been created to predict the translational behavior of the screwed connection of sandwich panels with I-profiled beam sections at both room and elevated temperatures.

The current model indicates the failure at 300°C due to degradation of the screw material. There are several possibilities to increase the fire resistance of the structure. The first solution is to use intumescent paints for the beam flange. These coatings are designed to swell or expand into thick foamed char upon exposure to heat, protecting the substrates against fire by insulation and providing a protective barrier to heat transfer. Furthermore, increasing the thermal resistance of other materials such as foams and facings can lead to a significant rise in the fire rating. Last but not least, using high-strength bolt materials can postpone the failure of the structure. In this study, the material for facings, beam flange and screw has been considered to be similar.

The FE model needs to be validated via testing before it can be used further for parametric investigation or incorporated into the sandwich panels system for investigating the behavior of translational connectors.

10. Acknowledgment

This project has received funding from the Research Fund for Coal and Steel under grant agreement No 751583.



REFERENCES

- [1] Großbrand bei Wiesenhof, Süddeutsche Zeitung, 29.03.2016.
- [2] Großbrand auf Messengelände in Düsseldorf, Rheinische Post, 07.06.2016.
- [3] EN 1993-1-2 Eurocode 3: Design of steel structures – Part 1-2: General rules – Structural fire design, 2005.
- [4] International Organization for Standardization, ISO 834-1:1999 Fire-resistance tests – elements of building construction – Part 1: General requirements, Geneva, 1999.
- [5] ABAQUS on-line documentations, version 6.13.
- [6] Wang, Y. C. and A. Foster. Experimental and numerical study of temperature developments in PIR core sandwich panels with joint, Fire Safety Journal, 2017, 1-14.